

Minilux light sensor for outdoor mounting

- **43-198 for connection to Minilux Control 18-093, Minilux Control 36-092 and Control 36-080**
- **24 V DC**
- **Screw terminal connection**
- **Protection class IP 54**

Minilux light sensor 43-198 is for outdoor lighting control.

The light sensor has screw terminal connection, so there is no need for extra junction boxes.

The light sensor has a IP54 protection class.

Please note!

If the light sensor is connected to a class I Minilux Control (18-093), the wiring to the sensor must be set up as for power current.

Placement:

By placement on a wall you must make compensation for the shadow effects on the sensor: (see fig. 1)

The sensor must be placed notherly, because north is lightneutral in proportion to the sun's daily cycle east-south-west.

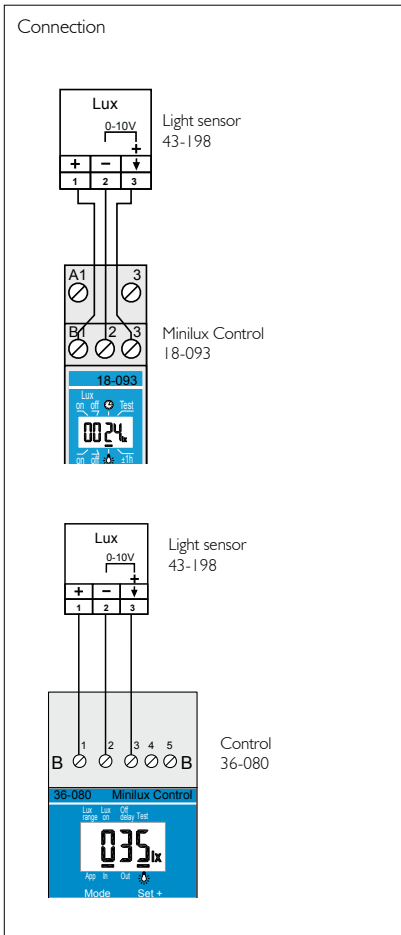

Technical data



Input

Supply voltage 24 V DC \pm 10 %

Output

Output voltage 0-10 V

Performance

Lux ranges: 3...300 lux, 30...3K lux
300...30K lux, 600...60K lux

Protection class IP 54

Connection Screw terminals

Distance from Control Max. 100 m

Cable: Class I Control 3 x 1,5 mm²

Cable: Class II Control 0,6 mm

Ambient temperature -40° C...+50° C

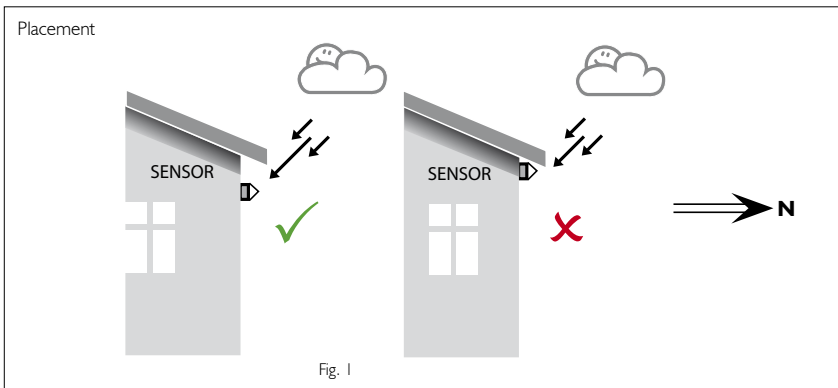
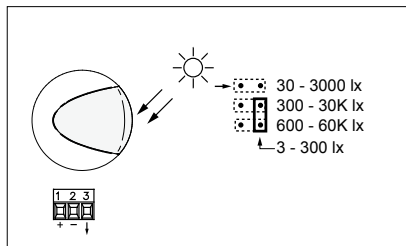
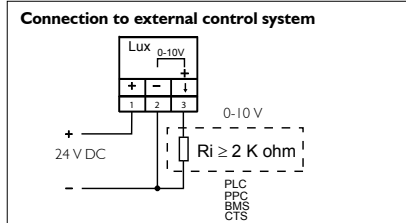

Order numbers

| Product | Type | EAN no. |
|----------------------|--------|-----------------|
| Minilux light sensor | 43-198 | 5703 102 203595 |